



BY-PASS VAV BOX MODEL KVAD-200-BP

PRESSURE DEPENDENT

STANDARD CONSTRUCTION

FRAME:

22 GA galvanized steel interlocking sections.

BLADES:

16 GA galvanized 2V type blades.

BEARINGS:

Bronze bearings.

AXLES:

12mm square zinc plated steel stud.

FINISH:

Mill galvanized.

INSULATION:

15mm clean liner fiber glass.

GASKETS:

Rubber foam gaskets on blade and on airflow side.

CONTROL ENCLOSURE:

NEMA1 control enclosure.

BYPASS PLENUM:

Sizes 14", 16" & 18" provided with a bypass plenum as standard design, with opening towards the inlet. Model: BY-PB

OPTIONS:

- 1) 20 GA galvanized casing.
- 2) Stainless steel construction grade 304 or 316.
- 3) Aluminum foil facing insulation 15mm or 25mm.
- 4) 1" (25mm) clean liner fiber glass insulation.
- 5) Polymer closed cell foam.
- 6) Double wall construction fiber glass covered with perforated sheet.
- 7) Metal noising at outlet to cover insulation edges.
- 8) Balancing damper on bypass side.
- 9) Flanged discharge (Duct flange or Duct mate).
- 10) Slip & drive connection.
- 11) Stand alone control with room thermostat.
- 12) BACNET control with room thermostat.
- 13) Lon control with room thermostat.
- 14) Sizes 6", 8", 10" & 12" can be provided with a bypass plenum. Model: BY-PB.
- 15) Bypass plenum could be provided with damper. Model: BY-PB-D.

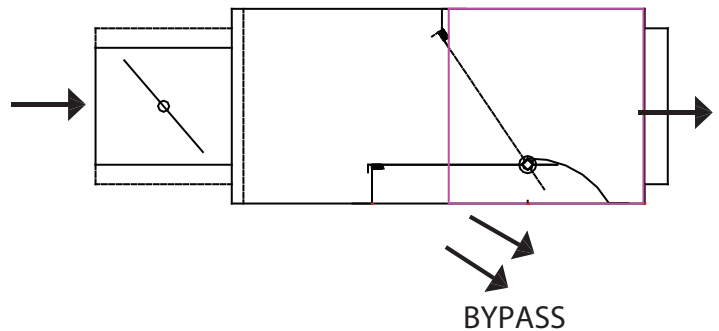

MINIMUM SIZES:

6" Round inlet.

MAXIMUM SIZES:

18" Rectangular inlet.

Product tested in Intertek Lab in accordance with ARI Standard 880.

MODEL KVAD-200-BP

DIMENSIONAL DATA

STANDARD

UNIT SIZE	D	W	H	L	W1	H1	L1	B	C
6	150	250	250	550	200	200	735	200	200
8	200	250	250	550	200	200	735	200	200
10	250	300	300	550	250	250	735	250	250
12	300	350	350	750	300	300	935	300	300

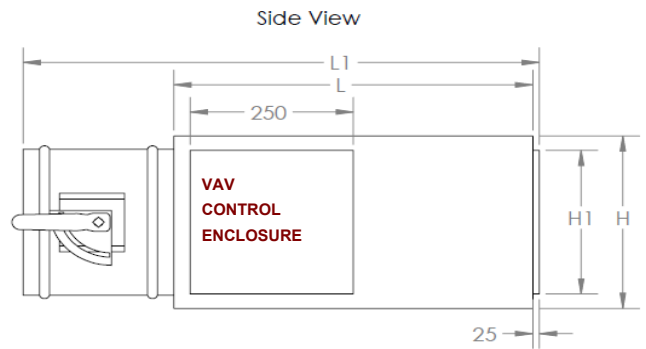
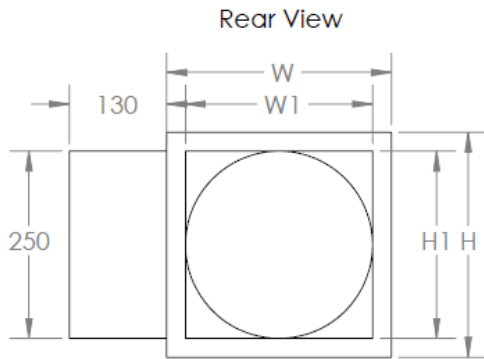
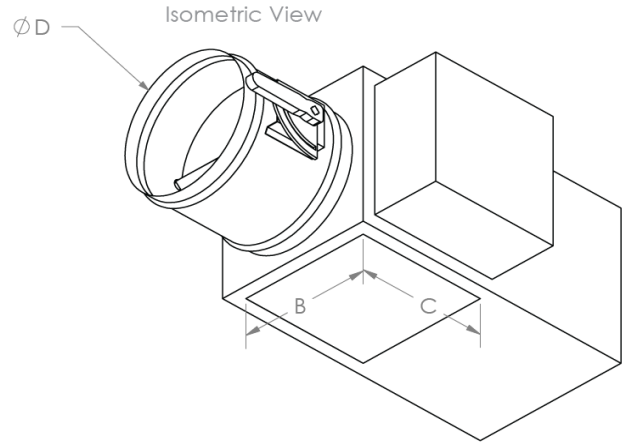

WITH BYPASS PLENUM (BY-PB)

UNIT SIZE	D	W	H	L	W1	H1	L1	H*	E
6	150	250	250	550	200	200	735	330	400
8	200	250	250	550	200	200	735	330	400
10	250	300	300	550	250	250	735	380	400
12	300	350	350	750	300	300	935	430	600
14	350	400	400	750	350	350	935	500	600
16	450x350	500	400	800	450	350	940	500	650
18	550x350	600	400	800	550	350	940	500	650

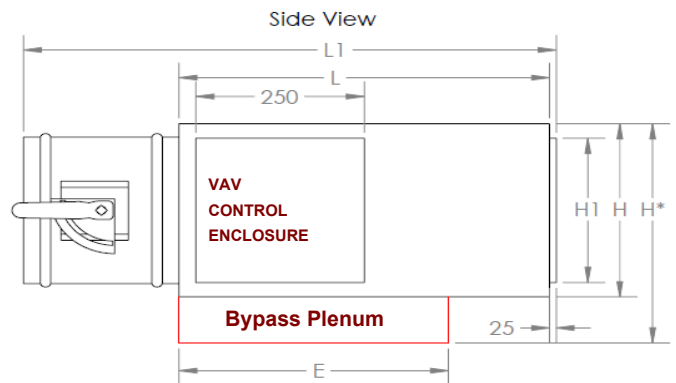
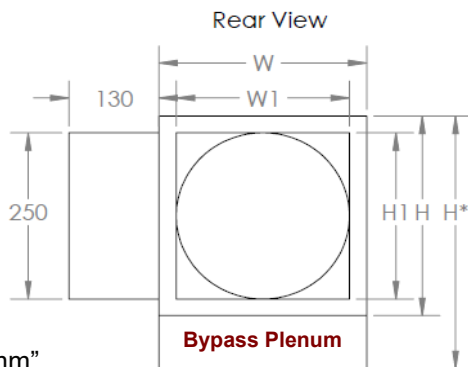
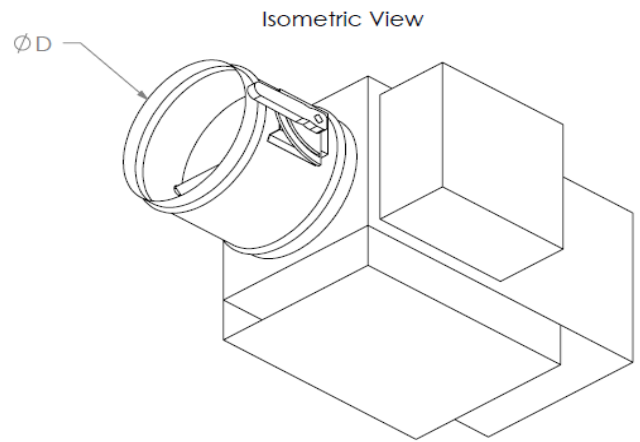

NOTES:

- 1) All sizes are in "mm"
- 2) Sizes 14, 16 & 18 are supplied with Bypass Plenum as standard *
- 3) Bypass plenum are supplied with 15mm Clean fiber.*
- 4) Bypass plenum opening are toward the Inlet opening as standard*
- 5) Size 16 & 18 have rectangular inlet

* Customized construction is available. Please refer to KBE Engineer.



MODEL KVAD-200-BP-SA

WITH INTEGRAL SOUND ATTENUATOR

DIMENSIONAL DATA

STANDARD WITH INTEGRAL SOUND ATTENUATOR

UNIT SIZE	D	W	H	L	W1	H1	L1	B	C
6	150	250	250	1100	200	200	1285	200	200
8	200	250	250	1100	200	200	1285	200	200
10	250	300	300	1100	250	250	1285	250	250
12	300	350	350	1100	300	300	1285	300	300

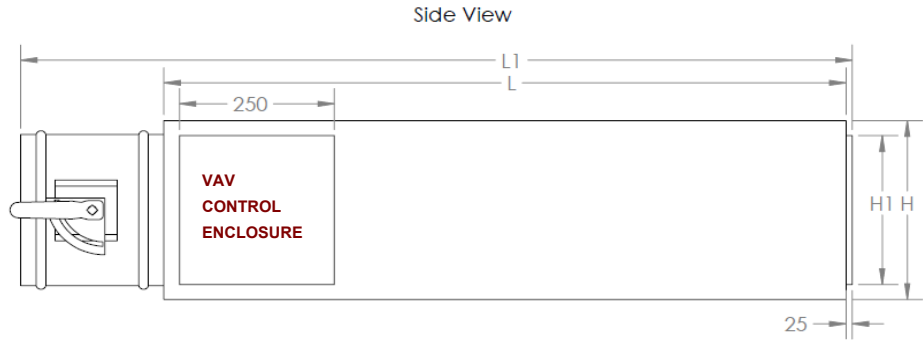
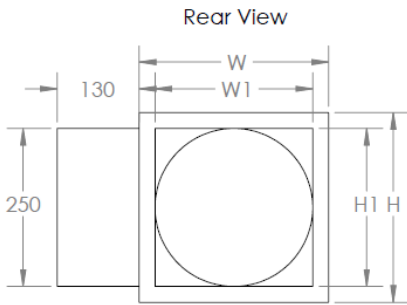
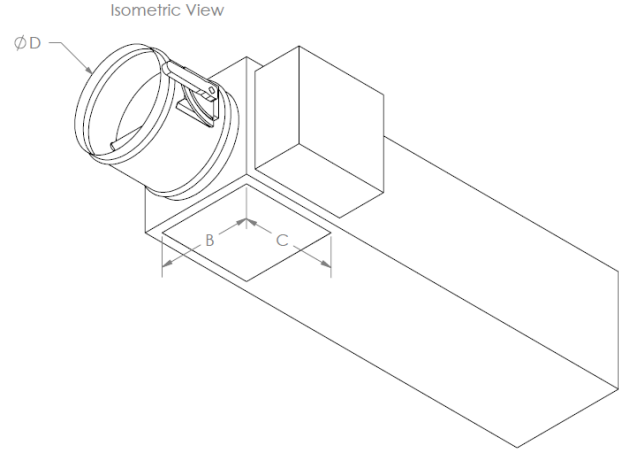

WITH INTEGRAL SOUND ATTENUATOR WITH BYPASS PLENUM (BY-PB)

UNIT SIZE	D	W	H	L	W1	H1	L1	H*	E
6	150	250	250	1100	200	200	1285	330	400
8	200	250	250	1100	200	200	1285	330	400
10	250	300	300	1100	250	250	1285	380	400
12	300	350	350	1100	300	300	1285	430	600
14	350	400	400	1100	350	350	1285	500	600
16	450x350	500	400	1200	450	350	1340	500	650
18	550x350	600	400	1200	550	350	1340	500	650

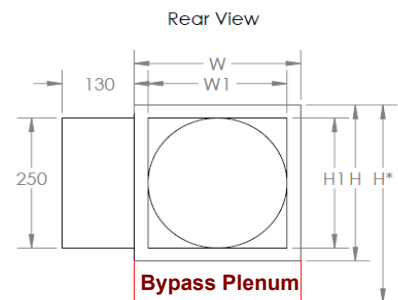
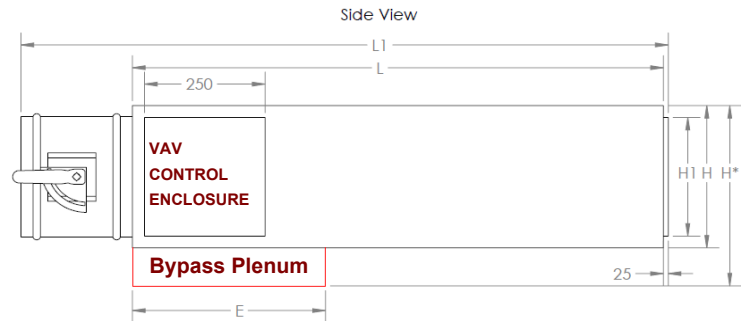
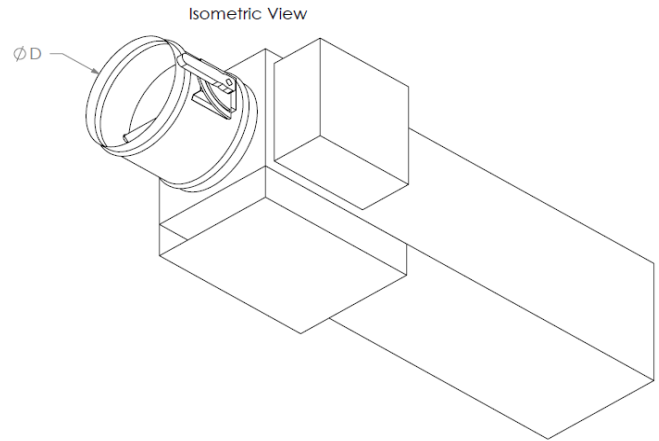

NOTES:

- 1) All sizes are in "mm"
- 2) Sizes 14, 16 & 18 are supplied with Bypass Plenum as standard *
- 3) Bypass plenum are supplied with 15mm Clean fiber.*
- 4) Bypass plenum opening are toward the Inlet opening as standard*
- 5) Size 16 & 18 have rectangular inlet

* Customized construction is available. Please refer to KBE Engineer.

MODEL KVAD-200-BP-EH

WITH ELECTRIC HEATER

DIMENSIONAL DATA

STANDARD WITH ELECTRIC HEATER

UNIT SIZE	D	W	H	L	W1	H1	L1	B	C
6	150	250	250	1100	200	200	1285	200	200
8	200	250	250	1100	200	200	1285	200	200
10	250	300	300	1100	250	250	1285	250	250
12	300	350	350	1100	300	300	1285	300	300

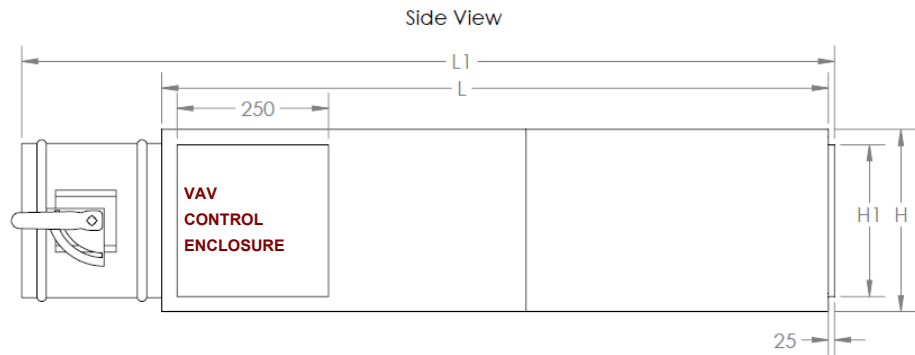
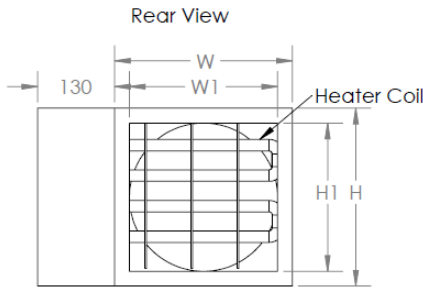
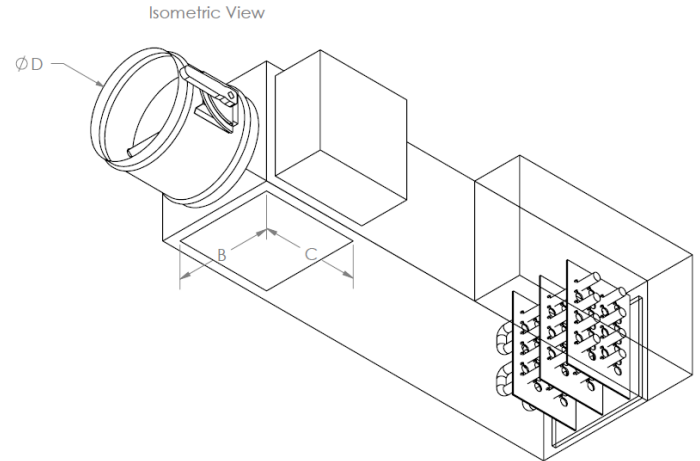

WITH ELECTRIC HEATER WITH BYPASS PLENUM (BY-PB)

UNIT SIZE	D	W	H	L	W1	H1	L1	H*	E
6	150	250	250	1100	200	200	1285	330	400
8	200	250	250	1100	200	200	1285	330	400
10	250	300	300	1100	250	250	1285	380	400
12	300	350	350	1100	300	300	1285	430	600
14	350	400	400	1100	350	350	1285	500	600
16	450x350	500	400	1200	450	350	1340	500	650
18	550x350	600	400	1200	550	350	1340	500	650

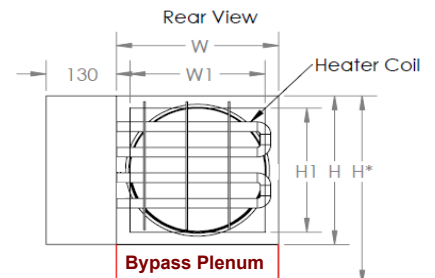
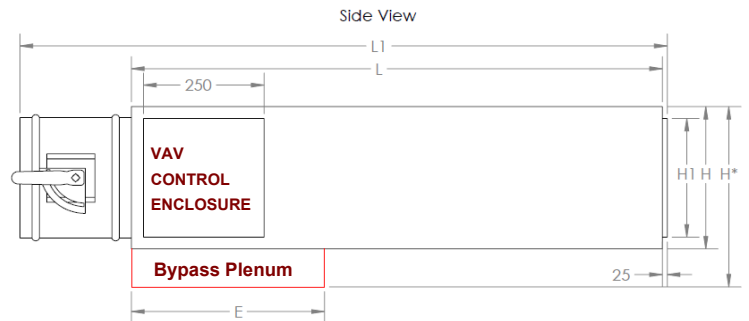
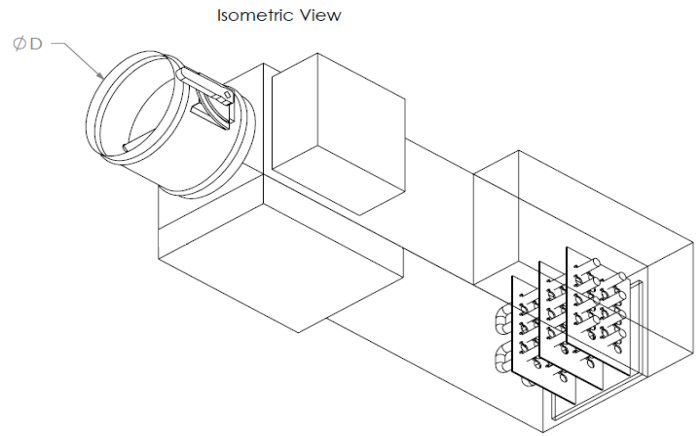

NOTES:

- 1) All sizes are in "mm"
- 2) Sizes 14, 16 & 18 are supplied with Bypass Plenum as standard *
- 3) Bypass plenum are supplied with 15mm Clean fiber.*
- 4) Bypass plenum opening are toward the Inlet opening as standard*
- 5) Size 16 & 18 have rectangular inlet

* Customized construction is available. Please refer to KBE Engineer.



MODEL KVAD-200-BP SELECTION DATA

SOUND DATA

Unit Size	Airflow Cfm-(L/s)	Min Operating Pressure In. Wg. --(Pa) (BYPASS Closed)	Sound Power Levels (db)													
			Discharge Octave Bands (Bypass Closed)							Radiated Octave Bands (Bypass Closed)						
			2	3	4	5	6	7	NC	2	3	4	5	6	7	NC
6	200 -(94)	0.001--(0.1)	49	37	28	26	19	17	<15	43	31	28	24	18	18	<15
	300 -(142)	0.001--(0.2)	55	43	34	29	22	18	<15	43	34	31	26	19	18	<15
	400 -(189)	0.001--(0.3)	55	47	40	28	22	19	<15	45	37	38	34	24	18	<15
8	300 -(142)	0.001--(0.1)	53	40	31	24	18	18	<15	40	32	23	23	18	17	<15
	500 -(236)	0.001--(0.2)	57	45	46	28	18	18	<15	40	32	25	24	18	17	<15
	700 -(330)	0.001--(0.3)	59	53	44	36	26	22	<15	44	39	31	29	21	18	<15
10	500-(236)	0.001--(0.1)	52	36	25	23	17	17	<15	40	33	24	24	18	18	<15
	700 -(330)	0.001--(0.2)	54	44	34	24	18	17	<15	40	33	26	24	18	18	<15
	1000- (472)	0.001--(0.3)	56	52	44	34	25	21	<15	45	36	35	28	21	18	<15
12	800- (378)	0.001--(0.1)	54	36	28	22	17	17	<15	41	36	31	26	19	18	<15
	1200 -(566)	0.001--(0.2)	56	43	38	26	19	17	<15	44	38	35	29	23	18	<15
	1600 -(755)	0.001--(0.3)	58	50	45	34	28	24	<15	50	42	39	31	23	18	<15
14	1500 -(708)	0.001--(0.1)	56	50	46	30	24	19	<15	41	35	34	24	19	18	<15
	2000 -(944)	0.001--(0.2)	60	56	53	38	34	30	<15	47	42	41	27	24	20	<15
	2500 -(1180)	0.001--(0.3)	64	62	58	45	41	38	18	53	48	47	34	28	22	<15
16	1800 -(849)	0.06 -- (15)	51	48	48	40	36	29	<15	46	39	38	33	29	19	<15
	2700 -(1274)	0.13 -- (32)	62	56	54	51	47	42	<15	55	49	45	44	37	30	19
	3600 -(1699)	0.24 -- (60)	67	63	60	56	54	51	21	62	57	52	49	44	39	27
18	2400 -(1133)	0.05 -- (13)	53	51	47	43	40	36	<15	50	43	38	33	24	20	<15
	3200 -(1510)	0.09 -- (22)	60	57	53	51	48	45	<15	58	51	46	42	33	27	20
	4400 -(2076)	0.17 -- (43)	68	65	61	58	56	53	22	66	59	54	48	42	37	30

Notes:

- * "Min Operating Pressure (in. Wg.)" is the static pressure difference between the terminal inlet and discharge with the damper wide open
- * Discharge Sound power data is the noise emitted from the unit discharge into the downstream duct with inlet Damper fully open.
- * Radiated Sound Power is the noise transmitted through the casing walls with inlet Damper fully open and bypass damper fully closed.
- * Performance data obtained from test conducted in accordance with ARI Standard 880-2011 and ASHREA 130-2008 in Intertek Lab in N.Y- under report No. 102153542crt
- * NC Values calculated based ARI Standard 885-2008 Appendix E1 Typical sound Attenuation Values (shown at right)

AHRI Standard DEDUCTIONS							
Discharge Noise Criteria (NC)							
CFM	2	3	4	5	6	7	
<300	24	28	39	53	59	40	
300-700	27	29	40	51	53	39	
>700	29	30	41	51	52	39	
Radiated Noise Criteria (NC)							
Mineral Fiber Ceiling	2	3	4	5	6	7	
	18	19	20	26	31	36	



BY-PASS VAV BOX MODEL KVAD-200-BP

ORDER INFORMATION

MODEL	CONST	LINING	PERFORATED	FLANGE	SIZE (INCH)
--					
KVAD-200 KVAD-200-SA KVAD-200-EH	CL: Clean Liner 1.5 cm (STD) CL-2.5: Clean Liner 2.5 cm AF-1.5: Aluminum Foil Lining 1.5 cm AF-2.5: Aluminum Foil Lining 2.5 cm		--: No Perforation PRF: With Perforated sheet	--: W/O Flange F: With Flange F-DM: With Duct Mate Flange	6 8 . . . 18

Product tested in Intertek Lab in accordance with ARI Standard 880.

AVAILABLE CONTROL

- STAND ALONE CONTROL WITH DIGITAL DISPLAY THERMOSTAT WITH CLASS II TRANSFORMER 24/220V
- BACNET CONTROL WITH DIGITAL DISPLAY THERMOSTAT WITH CLASS II TRANSFORMER 24/220V
- LON CONTROL WITH DIGITAL DISPLAY THERMOSTAT WITH CLASS II TRANSFORMER 24/220V