



MODEL K75 TYPE LC, LCR & LCO

UL CLASSIFIED 3 HOURS RATING

APPLICATION

MODEL K75-L IS APPROVED FOR USE IN WALLS, FLOORS AND PARTITIONS WITH FIRE RESISTANCE RATINGS OF 4 HOURS AND LESS.

STANDARD CONSTRUCTION

FRAME.

4-1/4" (108mm) Maximum X 22 (0.85mm) gauge Galvanized steel channel.

BLADES.

22 (0.85mm) gauge Galvanized steel curtain type out of the air stream.

FINISH.

Mill.

CLOSURE SPRINGS.

301 Stainless Steel Spring.

FUSIBLE LINK.

Standard 165° F (74° C). Other available.

MOUNTING.

Vertical & Horizontal.

MINIMUM SIZE.

Model K75 C --- 4"Wx 4"H (100 x100mm).
Model K75 CR ---- diameter 3" (76mm).
Model K75 CO ---- diameter 3" (76mm).

MAXIMUM SIZE.

Model K75C Single Section:

Vertical Installation
58"Wx 52"H (1473 x 1321mm).

Model K75CR & CO Single Section:

Vertical Installation
Diameter 52" (1321mm)

Model K75C Single Section:

Horizontal Installation
28"W x 26"H (711 x 660mm)

Model K75CR & CO Single Section:

Horizontal Installation
Diameter 26" (660mm)

FEATURES.

*Each damper is marked with a 3 hours UL 555 Classified fire damper label.

*Meets all UL and NFPA criteria for primary fire dampers in walls and floors with fire resistance ratings of 4 hours and less.

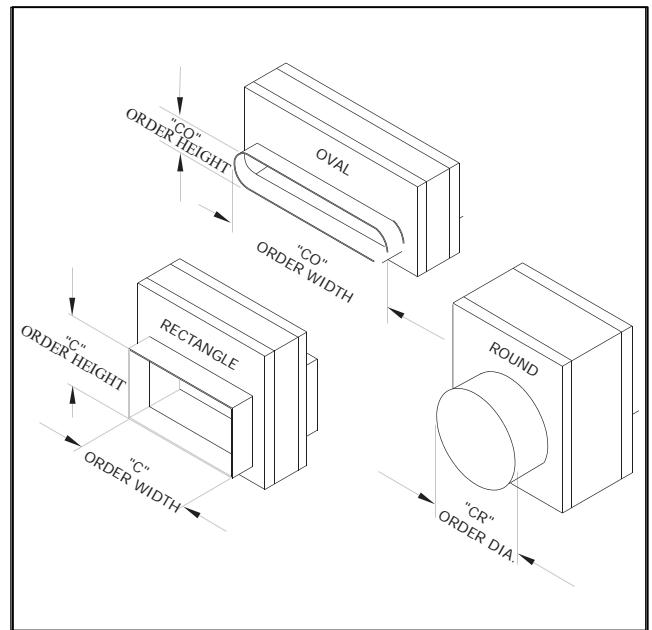

VARIATION.

All UL Classified fire dampers must be fabricated in accordance with UL procedures. Available variation are limited to those incorporated in the approved procedures.

Approved variations available at additional cost are :

*Factory furnished sleeves.
Sleeves are available in 10 (3mm) through 20 (1mm) gauge steel and in lengths required for the specific application.

NOTES.

* Dampers furnished approximately 1/4"(6mm) smaller than given duct dimension

* Refer to the KBE Installation Instruction and supplements for complete installation details.

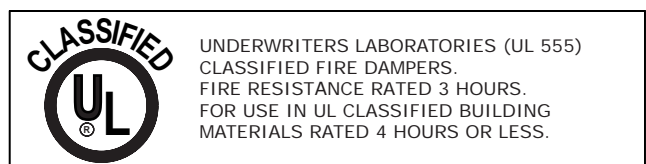
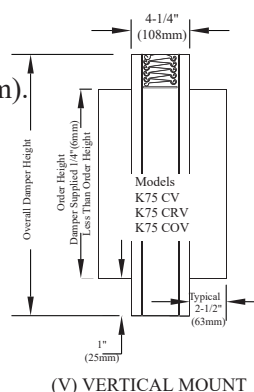

MODEL K75 TYPE LCR & LCO

ROUND SIZING CHART

ORDER DIAMETER Inch (mm)	DAMPER FRAME WIDTH X HEIGHT Inch (mm)
4" (102)	6 X 6" (152x152)
5" (127)	7 X 7" (178x178)
6" (152)	8 X 8" (203x203)
7" (178)	9 X 9" (229x229)
8" (203)	10 X 11" (254x279)
9" (229)	11 X 12" (279x305)
10" (254)	12 X 13" (305x330)
11" (279)	13 X 14" (330x356)
12" (305)	14 X 15" (356x381)
13" (330)	15 X 16" (381x406)
14" (356)	16 X 17" (406x432)
15" (381)	17 X 18" (432x457)
16" (406)	18 X 19" (457x483)
17" (432)	19 X 21" (483x533)
18" (457)	20 X 22" (508x559)
19" (483)	21 X 23" (533x584)
20" (508)	22 X 24" (559x610)
21" (533)	23 X 25" (584x635)
22" (559)	24 X 26" (610x660)
23" (584)	25 X 27" (635x686)
24" (610)	26 X 28" (660x711)
25" (635)	27 X 29" (686x737)
26" (660)	28 X 30" (711x762)
27" (686)	29 X 32" (737x813)
28" (711)	30 X 33" (711x838)

ORDER DIAMETER Inch (mm)	DAMPER FRAME WIDTH X HEIGHT Inch (mm)
29" (737)	31 X 34" (762x864)
30" (762)	32 X 35" (813x889)
31" (787)	33 X 36" (838x914)
32" (813)	34 X 37" (864x940)
33" (838)	35 X 38" (889x965)
34" (864)	36 X 39" (914x991)
35" (889)	37 X 40" (940x1016)
36" (914)	38 X 42" (965x1067)
37" (940)	39 X 43" (991x1092)
38" (965)	40 X 44" (1016x1118)
39" (991)	41 X 45" (1041x1143)
40" (1016)	42 X 46" (1067x1168)
41" (1041)	43 X 47" (1092x1194)
42" (1067)	44 X 48" (1118x1219)
43" (1092)	45 X 49" (1143x1245)
44" (1118)	46 X 50" (1168x1270)
45" (1143)	47 X 52" (1194x1321)
46" (1168)	48 X 53" (1219x1346)
47" (1194)	49 X 54" (1245x1372)
48" (1219)	50 X 55" (1270x1397)
49" (1245)	51 X 56" (1295x1422)
50" (1270)	52 X 57" (1321x1448)
51" (1295)	53 X 58" (1346x1473)
52" (1321)	54 X 59" (1372x1499)

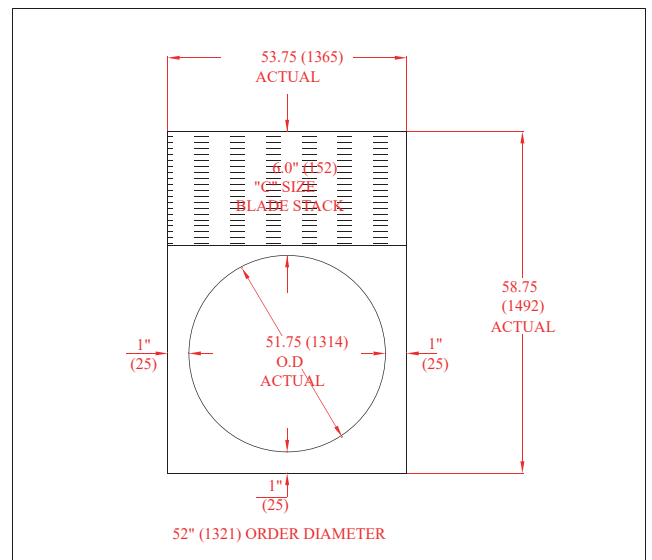
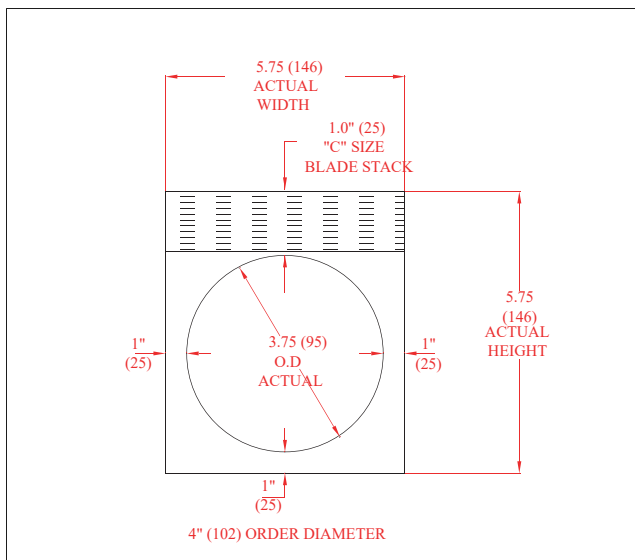

MODEL K75 PERFORMANCE DATA

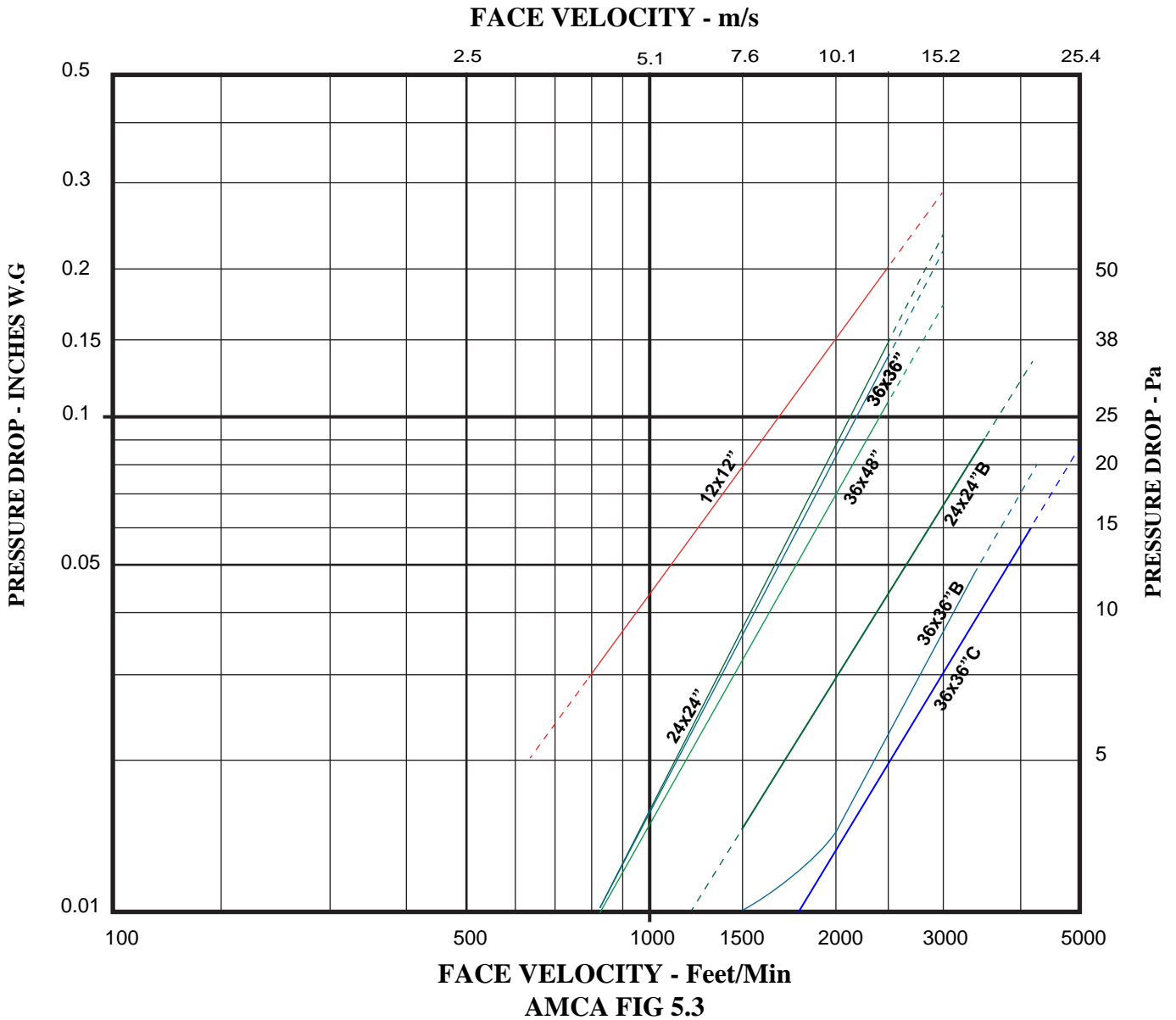

AMCA Test Figures

Figure 5.3 Illustrates a fully ducted damper. This configuration has the lowest pressure drop of the test configurations because entrance and exit losses are minimized by straight duct runs upstream and downstream of the damper.

Pressure drop for type C is applicable for Cr & CO

