

FIRE DAMPERS INSTALLATION INSTRUCTIONS

ATTACHING FIRE DAMPERS TO SLEEVES

Fire dampers must be attached to sleeves as shown in fig. 1. All four sides of the damper frame must be attached to the sleeve with one row of attachments on each side of the blade channel. Attachments must be spaced a maximum of 6" on centers and a maximum of 2" from corners. A minimum of 4 attachments (2 on each side of the blade channel) per side (16 per damper) are required. One of the methods of attachment shown below must be used.

- Tack or spot welds.
- No. 10 sheet metal screws.
- 1/4" bolts and nuts.
- 3/16" steel pop rivets.

SECURING FIRE DAMPER AND SLEEVES TO WALL AND FLOOR OPENINGS

Fire damper and sleeve assemblies must be installed in wall and floor openings using retaining angles on each side of the wall or floor as described below:

- Retaining angles must be a minimum of 16 gauge steel and have a minimum of 1 1/2" x 1 1/2" legs.
- Retaining angles must be attached to the sleeve using the procedures and methods described hereunder. The angles must be attached to all 4 sides of the sleeve with butt joints at each corner. A minimum of two attachments are required on each side, top and bottom. The angles need not be attached to each other at the corners.
- Retaining angles must completely cover the clearance space between the sleeve and the wall/floor opening, plus overlap the wall/floor a minimum of 1". This coverage includes all corners (fig. 2).
- Retaining angles should not be fastened to the wall/floor material. The angles should only sandwich the wall/floor and allow for damper/sleeve expansion during periods of intense heat.
- For grille installation, angle legs may be reversed and one leg inserted into the wall/floor opening providing the required clearance is maintained between angle leg fasteners and the wall/opening.

CONNECTING DUCTS TO FIRE DAMPER SLEEVE

- For grille installation, angle legs may be reversed and one leg inserted into the wall / floor opening providing the required clearance is maintained between angle leg fasteners and the wall / opening.

MULTIPLE SECTIONS FIRE DAMPERS

When multiple sections are shipped unassembled, installer shall fasten dampers together.

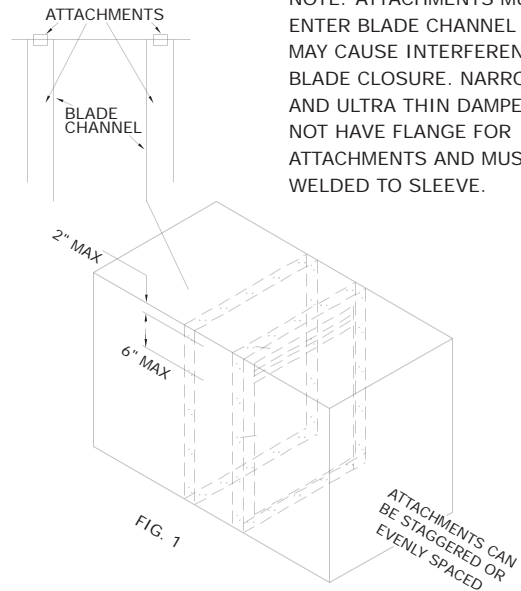

NOTE: ATTACHMENTS MUST NOT ENTER BLADE CHANNEL OR THEY MAY CAUSE INTERFERENCE WITH BLADE CLOSURE. NARROW LINE AND ULTRA THIN DAMPERS DO NOT HAVE FLANGE FOR ATTACHMENTS AND MUST BE WELDED TO SLEEVE.

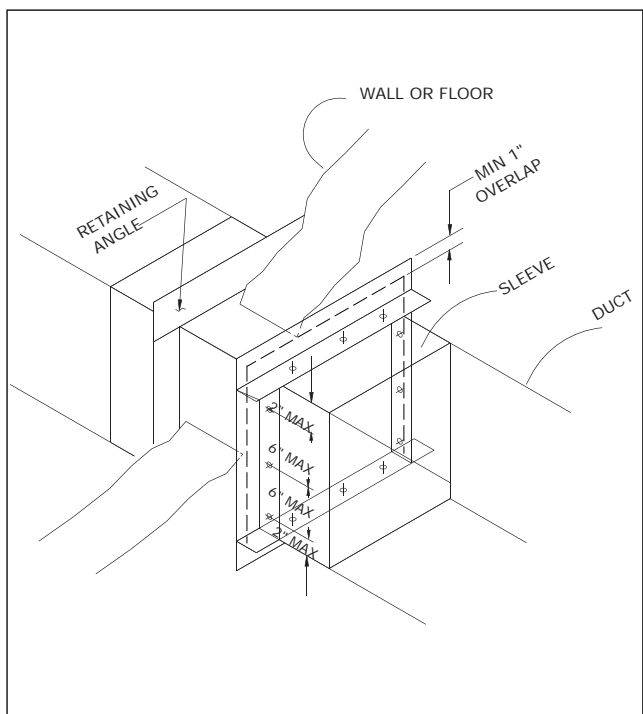



INSTALLATION INSTRUCTIONS
IN CONFORMANCE TO
UNDERWRITERS LABORATORIES
REQUIREMENTS



FIRE DAMPERS INSTALLATION INSTRUCTIONS

BREAKAWAY CONNECTIONS

Breakaway Style Transverse Joints

-Transverse joints illustrated at right have always been approved as breakaway connections. SMACNA testing has also approved the following variations as breakaway connections.

-Standing "S" joints can be applied with no. 10 sheet metal screws (through joint and duct) subject to the following limitations: Maximum 2 screws in each side and in bottom joint.

Transverse joints illustrated can be applied as top and bottom joints with Drive Slip - side joints in duct heights up to 20 inches.

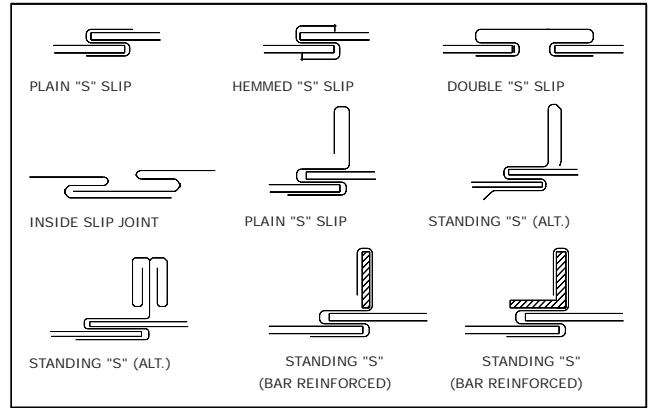

Round and Oval Duct Breakaway Connections

Round or flat oval ducts connected to type R, CR or CO damper collars may use no. 10 sheet metal screws as follows:

Ducts to 22" wide (or dia.) and smaller may use 3 screws.

Ducts larger than 22" wide (or dia.) may use 5 screws.

NOTE: All breakaway connections described may have duct sealant applied in accordance with SMACNA recommendations.



Manufactured Flanged System Breakaway

Flanged connection systems manufactured by Ductmate, Ward, and Nexus are approved as breakaway connections when installed as illustrated.

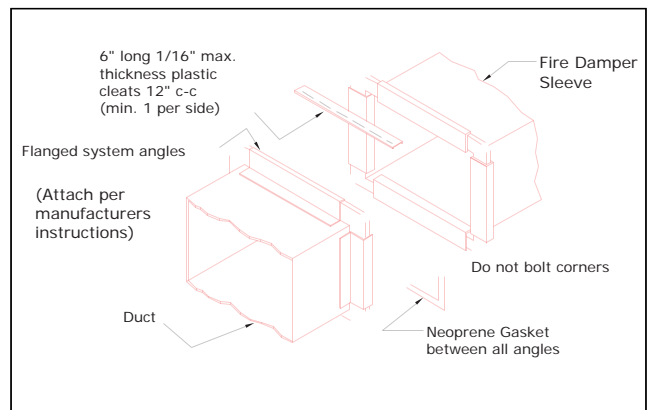
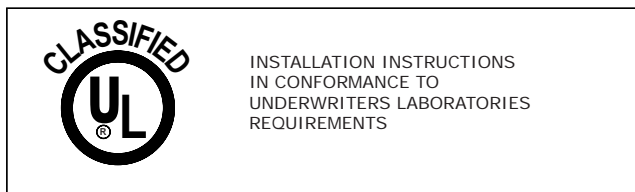

PROPRIETARY FLANGE SYSTEM BREAKAWAY CONNECTIONS (TDC by Lockformer, TDF by Engle)

TDC and TDF systems are approved as breakaway connections when installed as described in the TDC or TDF addendum to the SMACNA Duct construction Standards except the corners may not be bolted. Standard 6" metal clip may be used with spacing as shown in diagram.

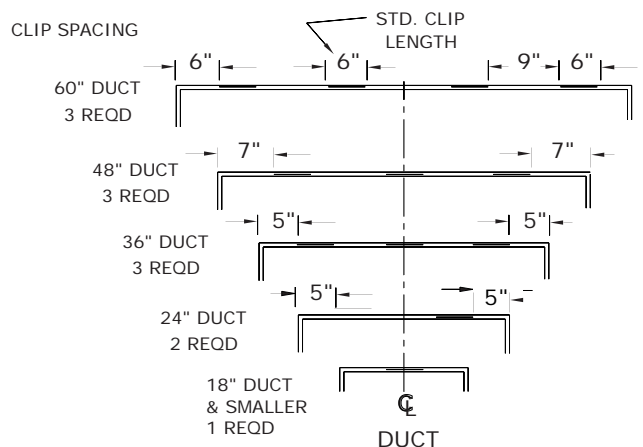
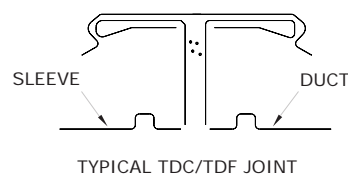

FIRE DAMPERS INSTALLATION INSTRUCTIONS

MOUNTING ANGLES

Secure mounting angles to the sleeve and not to the wall or floor. Mounting angles to frame the four sides of the sleeve on both faces.

When reverse mounting angles are used the size of the opening must be increased to maintain the specified expansion clearance between the angle / fasteners and the opening. Angles shall be a minimum of 1 1/2" x 1 1/2" x 16 gauge on dampers 36" x 50" and smaller. For dampers greater than 36" x 50", angles to be a minimum of 1 1/2" x 1 1/2" x 14 ga. Fasten angles to the sleeve using 1/4" dia. bolts and nuts or by welding with beads 1/2" in length, or with No. 10 steel sheet metal screws, or with 3/16" steel rivets. Fasteners or weld beads shall be 8" maximum on centers.

ACCESS

Suitable access must be provided for damper inspection and servicing. Where it is not possible to achieve sufficient size access, it will be necessary to install a removable section of duct.

CAULKING

Caulking is allowed between the mounting angles and the damper sleeve, and between the mounting angles and the floor or wall construction. Caulking is not allowed between the damper sleeve and the wall or floor inside the opening. Caulk shall be one of the following: Dow Corning RTV 732, or a UL approved substitute.

DUCT CONNECTION

The installation of the damper and all duct connections to the damper sleeve shall conform to NFPA-90A and the SMACNA Fire, Smoke and Radiation Damper Installation Guide. All duct connections shall also conform to UL555. Connecting ducts shall not be continuous but shall terminate at the damper sleeve. Duct connections to the sleeve will be either of the breakaway or rigid types, breakaway types are listed below.

The following determines if the connections are to be rigid or breakaway.

For rigid type duct connections, sleeve shall be a minimum of 16 GA on dampers not exceeding 36" wide or 24" high or 24" diameter and 14 ga on larger units. Dampers supplied with thinner sleeves will require a breakaway connection of the following type. Plain "S" slip, double "S" slip shown below. All connections not listed as breakaway shall be considered as rigid. Breakaway joints of the types shown below shall have no more than two No.10 (4.8 mm) diameter sheet metal screws on each side and on the top and bottom located in the center of the slip pocket and shall penetrate both sides of the slip pocket. Breakaway joints of the type shown below are permitted on the top and bottom of horizontal ducts (vertical dampers) with flat slips not exceeding 20 inches (508 mm) in length on the sides.

MAINTENANCE

Dampers shall be maintained in intervals as stated in NFPA-90A, Appendix B, unless local codes require more frequent inspections. Check the fuse link, check the stainless steel closure springs where furnished, cycle damper and check for free operation and complete closure, clean with mild detergent or solvent, secure damper open with fusible link.

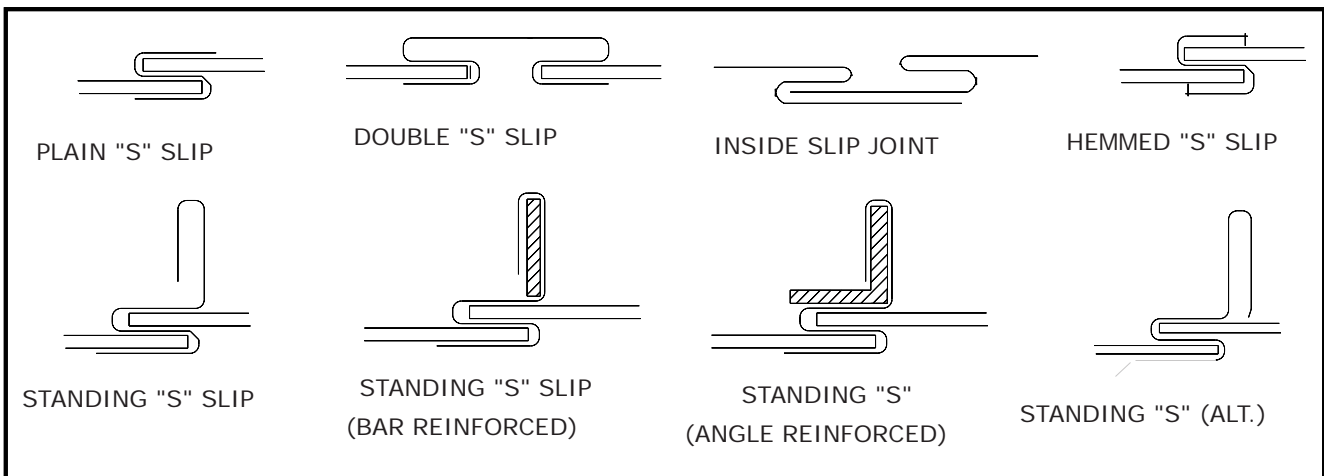

FIRE DAMPERS INSTALLATION INSTRUCTIONS

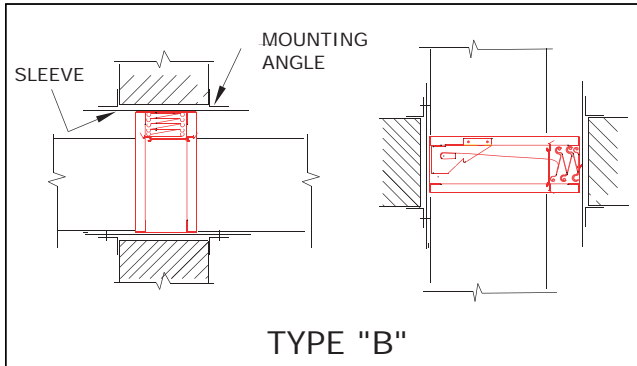

TYPE "B"

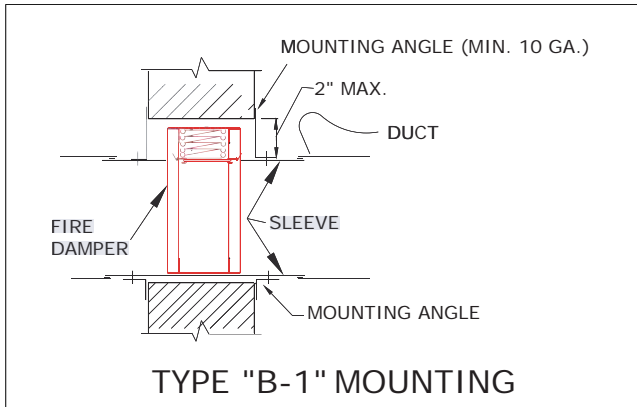

TYPE "B-1" MOUNTING

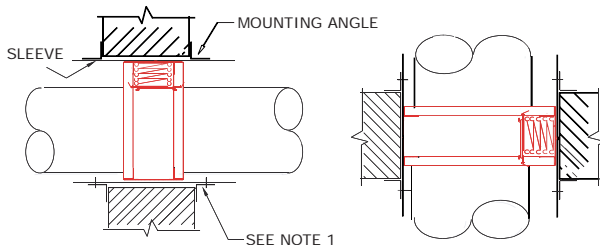

TYPE "CR"

The factory supplied 22 GA. collar to 18 GA cap The factory supplied 22 GA. collar to 18 GA cap connection under the following conditions:

1. Round unit duct diameters are no larger than 52"
2. Oval duct sizes are no larger than 58" W x 29"H.
3. Duct gauges shall conform to the SMACNA or ASHRAE duct standard.
4. Duct diameters of 22 inches (559 mm) and smaller shall have three (3) No. 10 (4.8 mm) diameter sheet metal screws evenly spaced around the circumference of the duct.
5. Duct diameters greater than 22 inches and up shall have five (5) sheet metal screws evenly spaced around the circumference of the duct.
6. Dampers outside of these restrictions (ie) multiple dampers and special size and application dampers must use a 4" wide drawband connection as shown in the SMACNA Fire, Smoke, and Radiation Damper Installation Guide.

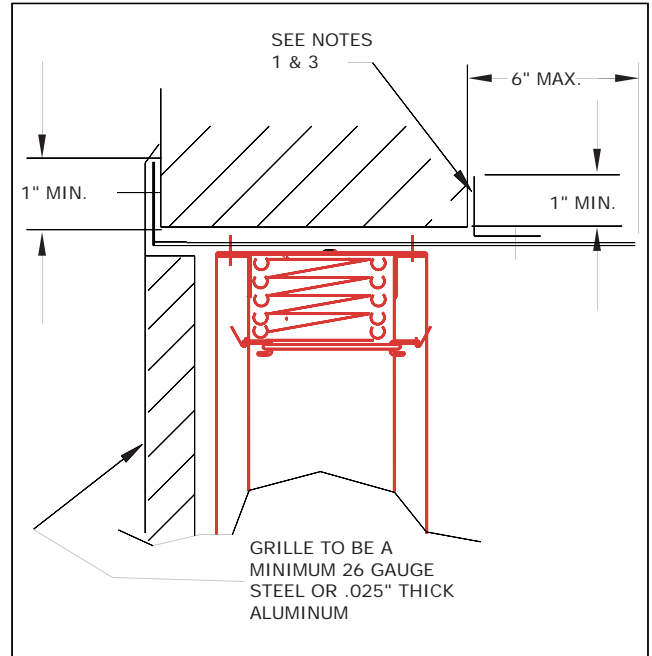

DAMPER BEHIND A GRILLE

1. Perimeter mounting angles to be a minimum of 1 1/2 x 1 1/2 x 16 GA on dampers 36" x 50" and smaller. For dampers greater than 36" x 50", angles to be a minimum of 1 1/2 x 1 1/2 x 14 GA.
2. Grille to flange fasteners cannot penetrate fire wall (see note 4).
3. Secure angles to sleeve only, so as to frame the wall opening. Fasten to the sleeve only using the same means as required for fastening the damper to the sleeve.
4. Grille to flange attachment by means of 1/4" dia. pop rivets, #8 sheet metal screws or #8 bolts and nuts. Fasteners to be plated steel or stainless steel, minimum two fasteners per side.

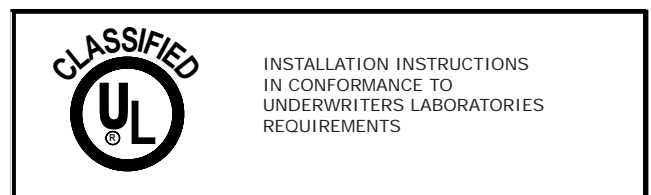



FIRE DAMPER MODEL K75 INSTALLATION INSTRUCTIONS

VERTICAL OR HORIZONTAL MOUNT 1-1/2 HRS RATING (FOR USE IN 2 HOURS OR LESS RATED PARTITIONS)

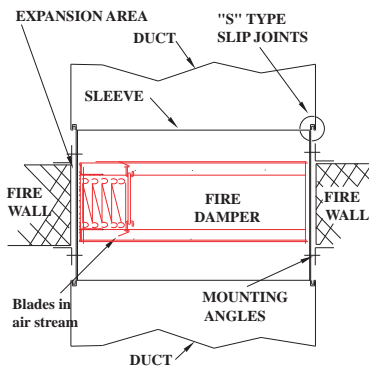
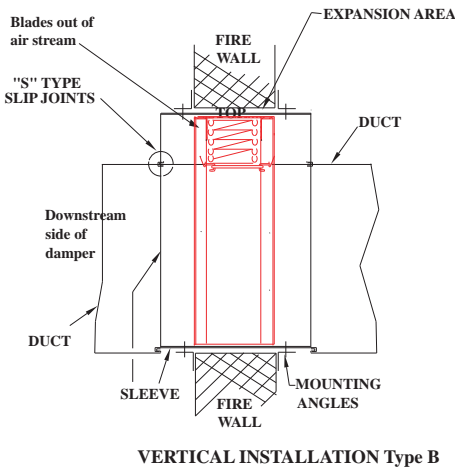
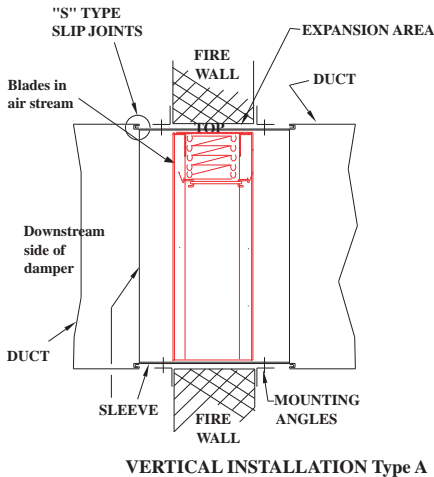

Damper shall be fastned to sleeve with No. 14x3/4 sheet Metal screws on 6" (150mm) center (max). No further than 2" (50mm) from end.

See Notes 2 & 3 for Duct connections.

Angle shall be a minimum of 1-1/2" x 1-1/2" x 1/16" (40x40x1.5mm) fasten to sleeve (see note 4 for expansion and overlap). Angles shall not be fastned to each other at the corners.

NOTES:

1. Sleeves shall be of the same gauge or heavier than the duct to which it attached. Gauge shall conform to SMACNA or ASHRAE standards.
2. When the following sleeve connections are used, the minimum gauge of the sleeve shall be 16 gauge on dampers not exceeding 36"W x 24"H (910x610mm) and 14 gauge on larger dampers.

- a. Angle reinforced standing seam.
- b. Angle reinforced pocket lock.
- c. Companion angles.
- d. Metal fasteners approximately 16" (400mm) on centers.

3. The following breakaway sleeve connections may be used on all systems :

- a. Plain "S" slip
- b. Hemmed "S" slip
- c. Bar slip
- d. Standing "S" slip
- e. Reinforced bar slip
- f. Angle slip
- g. Inside slip joint
- h. Double "S" slip

4. Clearance for expansion of 1/8" per foot (10mm per meter) of sleeve dimension is required. Angles should lap masonry a minimum of 1"(25mm) around the entire opening.

5. In multiple damper assemblies, units shall be fastened together using No.14 X 3/4" sheet Metal Screws.

6. Maximum sleeve extension is 6"(150mm) on both side of wall or floor opening.

7. Dampers may be installed in wall or partition (masonry or gypsum wallboard) or concrete floor.

8. The connecting ducts shall not be continuous, but shall terminate at the sleeve or frame.

9. Damper is rated for Static System

10. Dampers are supplied with factory mounted fusible 165°F (74°C) as standard

11. Installed damper units require operational checks upon completion to ensure proper functioning.

12. When unit is equipped with blade indicator switch care should be taken for points of field wiring and limit the voltage passing through the unit to 30Vdc with a max of 0.1amp, Class2 circuit (refer to Fig 5 for Wiring details)

MAXIMUM DAMPER SIZES

TYPE INSTALLATION	SINGLE UNITS IN INCHES	
	Height	Width
VERTICAL	60" (1524)	60" (1524)
HORIZONTAL	60" (1524)	60" (1524)
TYPE INSTALLATION	MULTIPLE UNITS	
	Height	Width
VERTICAL	120" (3048)	120" (3048)

Dim (--) are in mm

INSPECTION

- 1-Inspect damper for shipping damage
- 2-Inspect for proper size & model
- 3-Inspect installed damper for proper orientation as stated on damper label
- 4-Inspect for obstruction which could interfere with free operation & complete closure

**FIRE DAMPER MODEL K75
INSTALLATION INSTRUCTIONS**

**HORIZONTAL MOUNT - MULTIPLE SECTIONS
1-1/2 HRS RATING STATIC
(FOR USE IN 2 HOURS OR LESS RATED PARTITIONS)**

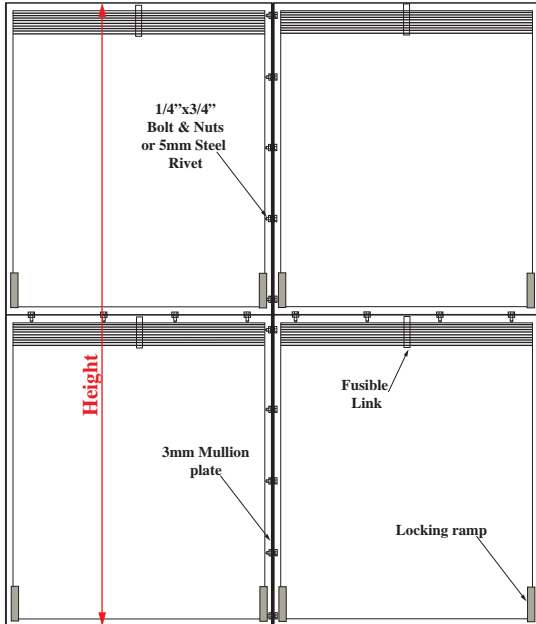

Damper shall be fastned to sleeve with steel Rivet 5mm on 6" center (max). No further than 2" (max) from end . Install Locking Ramp at top of the unit. Angle shall be a minimum of 50x50x1.5mm galvanized steel fasten to sleeve by No#10 x 1" sheet metal screw on 8" center (max), no further than 2" from end. Angles shall not be fastend to each other at the corners but against each other at the corner end. (see note 4 for expansion and overlap).

NOTES:

1. Sleeves shall be of the same gauge or heavier than the duct to which it attached. Gauge shall conform to SMACNA or ASHRAE standards.
2. When the following sleeve connections are used, the minimum gauge of the sleeve shall be 14 gauge (Max 10Ga) on dampers.
 - a. Angle reinforced standing seam.
 - b. Angle reinforced pocket lock.
 - c. Companion angles.
 - d. Metal fasteners approximately 16" (400mm) on centers.
3. The following breakaway sleeve connections may be used on all systems with a minimum of 16Ga sleeve thickness :
 - a. Plain "S" slip
 - b. Hemmed "S" slip
 - c. Bar slip
 - d. Standing "S" slip
 - e. Reinforced bar slip
 - f. Angle slip
 - g. Inside slip joint
 - h. Double "S" slip

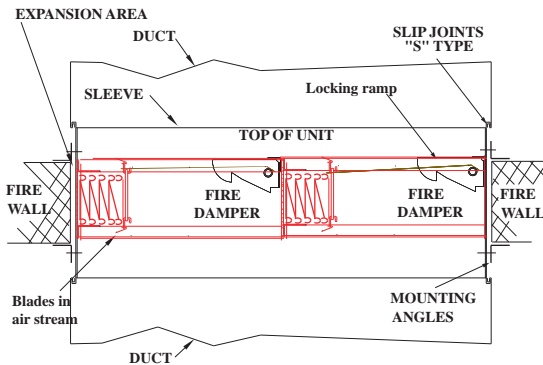

HORIZONTAL INSTALLATION

4. Clearance for expansion of 1/8" per foot of sleeve dimension is required. Angles should lap masonry a minimum of 1" around the entire opening.
5. In multiple damper assemblies, units shall be fastened together using 1/4" X 3/4" Bolts & nuts or 5mm Steel Rivet. A mullion plate of 3mm thick shall be used between mating dampers Frames (Height Dimension) when assembling 4 sections on 6"OC, 1"from end .
6. Maximum sleeve extension is 6" on both side of floor opening.
7. Dampers to be installed in concrete floor.
8. The connecting ducts shall not be continuous, but shall terminate at the sleeve or frame.
9. Damper is rated for Static System
10. Dampers are supplied with factory mounted fusible link 165°F (74°C) as standard
11. Installed damper units require operational checks upon completion to ensure proper functioning.
12. When unit is equipped with blade indicator switch care should be taken for points of field wiring and limit the voltage passing through the unit to 30Vdc with a max of 0.1amp, Class2 circuit (refer to Fig 5 for Wiring details).



MAXIMUM DAMPER SIZES		
TYPE	MULTIPLE UNITS	
INSTALLATION	Width	Height
HORIZONTAL	68"	96"
Manufactured out of 4 sections with max size of 34" (W) x 48" (H)		
For larger Opening Refer to Installation with Mullion frame Installation Instruction		

INSPECTION

- 1-Inspect damper for shipping damage
- 2-Inspect for proper size & model
- 3-Inspect installed damper for proper orientation as stated on damper label (TOP OF UNIT)
- 4-Inspect for obstruction which could interfere with free operation & complete closure

FIRE DAMPER MODEL K75 INSTALLATION INSTRUCTIONS

HORIZONTAL MOUNT WITH MULLION FRAME 1-1/2 HRS RATING STATIC (FOR USE IN 2 HOURS FLOOR OPENING)

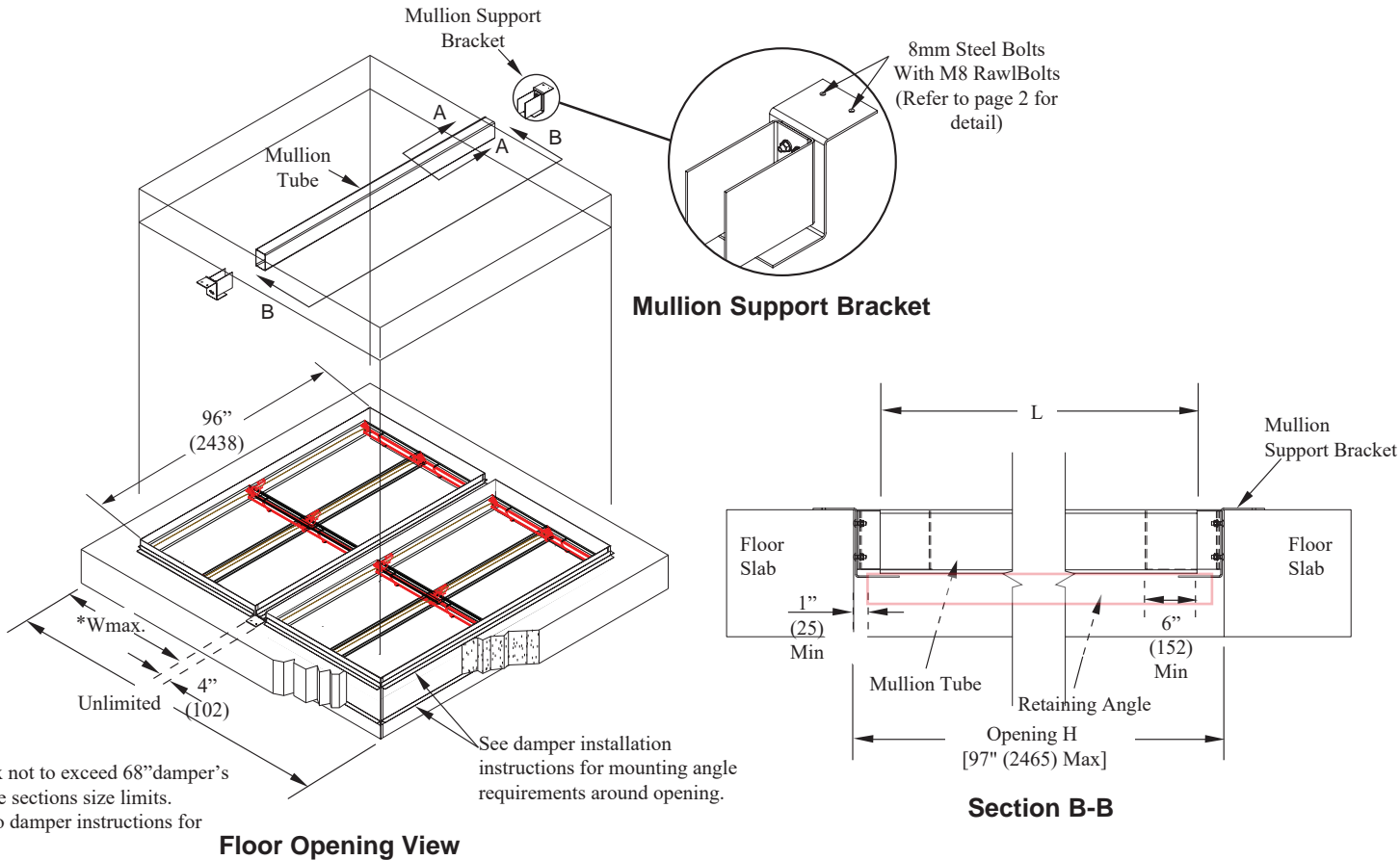

Application

Support mullions allow oversized openings in fire resistant rated floors to be subdivided into smaller openings that do not exceed the fire damper's maximum rated size limits. Whenever the duct size exceeds the maximum damper width, the opening must be divided into two or more separate openings with a mullion installed between horizontally mounted damper sections. The support mullion consists of a structural steel tube and two mullion support brackets. Maximum mullion spans must not exceed 97" (2465). The mullions are not intended to be in the airstream and are not part of the duct work. The horizontal steel mullion is intended for use in fire resistant floors rated to a maximum of 2 hours.

General Installation

Insert one mullion support bracket into each end of the mullion tube allowing the tube to float between the brackets. DO NOT fasten the brackets to the tube in any way. Locate in the opening to provide correct expansion clearance for the dampers. Refer to Damper Installation Instructions for details. Drill 1/16" (8) diameter holes in the mullion support brackets for anchoring. Drill 1/2" (12.5) diameter holes in the Concrete and introduce the **M8 RawlBolt** (8mm steel concrete anchors) for anchoring.

Each bracket must be anchored to concret in at least 2 places with a M8x70mm bolts. (Construction Details figure 2).

Retaining Angle on the **BOTTOM** of the mullion Frame shall be cut short to allow 1/8 in. per ft expansion clearance at ends, if the angles are located within the confines of the floor opening. The retaining angles at top of floor at the mullion are to overlap the floor at each end by min 1 in.

Galvanized coat structural steel mullion tube in accordance with local code requirements.

NOTE: Size in () are in mm

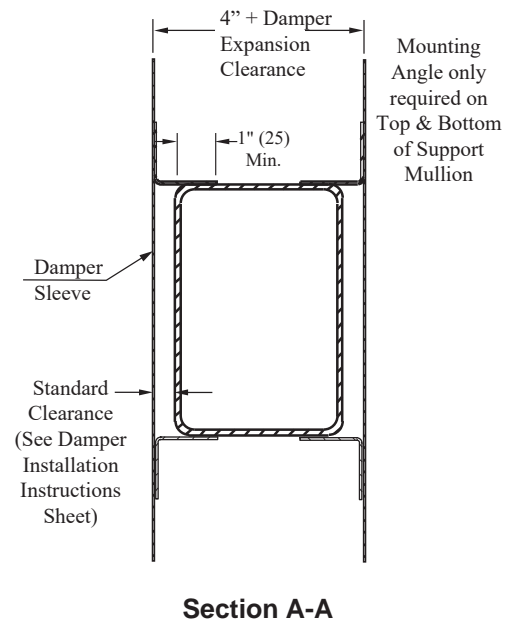

FIRE DAMPER MODEL K75
INSTALLATION INSTRUCTIONS

HORIZONTAL MOUNT WITH MULLION FRAME
1-1/2 HRS RATING STATIC
(FOR USE IN 2 HOURS FLOOR OPENING)

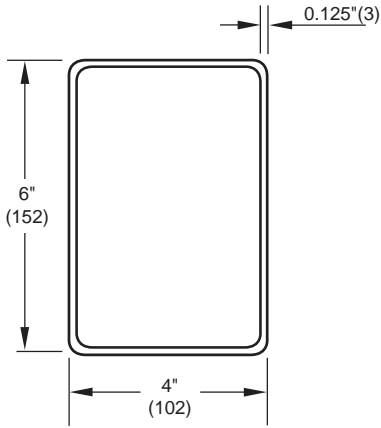

Figure 1: Mullion Tube

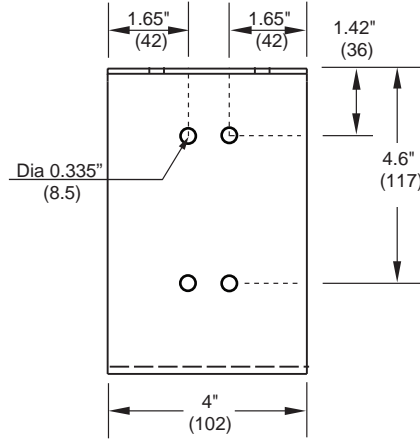

Figure 3: Shelf Bracket

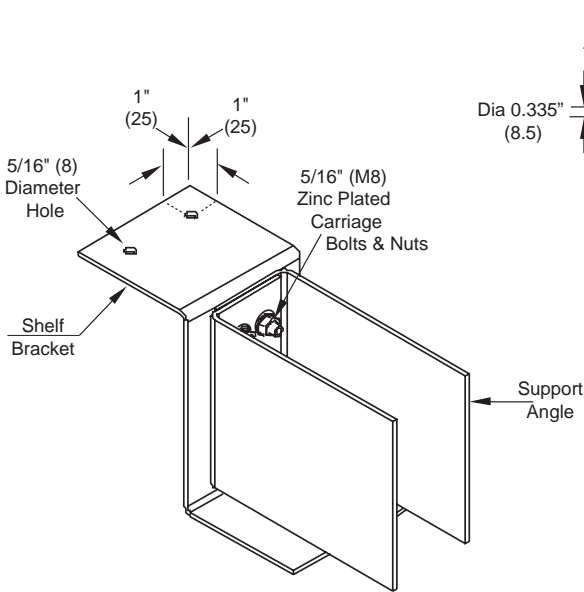
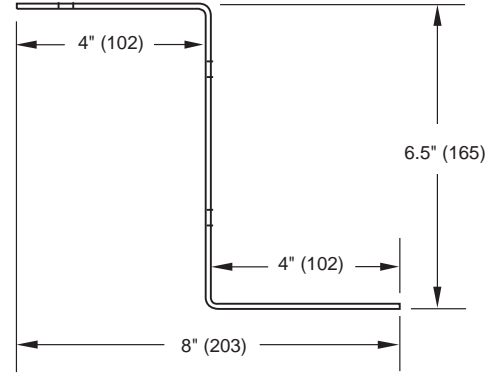

Figure 2: Mullion Support Bracket

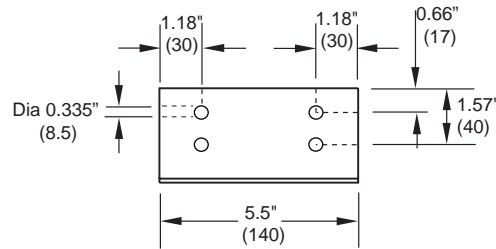

Figure 4: Support Angle



Construction

Fabricate mullion tubes from 6" x 4" x 1/8" thick (152 x 102 x 3) hot rolled steel tubing (Construction Fig 1). Size mullion tube to be a $2 \pm 1/2$ " (51 ± 13) shorter than the height of the rough opening. Fabricate two mullion support brackets per each mullion tube from 10 gauge (3.5) galvanized steel (Construction Details Fig 2). The brackets are to be assembled from one shelf bracket and from two support angles (See Construction Details Fig 3 & 4). The shelf bracket and support angles must be bolted together with minimum 5/16" x 1" (M8 x 25) diameter zinc plated or stainless steel carriage bolts to create the mullion support bracket. The mullion tube must overlap each support bracket by a minimum of 6" (152) (See Detail B-B).

Note: M8 Bolt =8mm



OPERATION & MAINTENANCE MANUAL FIRE DAMPER K75 SERIES

Regular maintenance is essential to ensure that a building's life-safety system will perform as intended under fire conditions. Regular maintenance should include periodic testing of all equipment associated with the life-safety system such as fire dampers. The interval of testing and maintenance varies widely depending on the duration of system operation, condition of fresh air, amount of dust in return air, and other factors. NFPA 80 recommends testing of all fire dampers 1 year after installation and then once every four years as a minimum.

SHIPPING INSPECTION

When receiving the Fire Dampers, please do the proper checking on the dampers before installation by following these steps:

- 1- Inspect the damper for shipping damage.
- 2- Check for proper Models & Sizes.
- 3- Inspect for obstruction which could interfere with free operation and complete closure.
- 4- Manually cycle the damper as follows:
 - a- Place the fire damper horizontally against a wall or solid ground with blade lock downward
 - b- Hold the blade firmly
 - c- Remove the fusible link by unlocking the attachment
 - d- Release the blade spontaneously - Do not remove your hand slowly it might harm the spring.
 - e- Damper should close completely.
 - f- Reopen the damper.
 - g- **Make sure to place & lock the fusible link** in the same way as it was before the testing.

MAINTENANCE

- Check closure springs. If defective, repair or replace.
- Inspect for obstruction which could interfere with free operation and complete closure.
- Operate the damper by removing the fusible link and allowing the blades to drop or close.
(Caution: keep fingers and hands out of the blade package travel path.)
- Check the damper for rust and/or corrosion.
- Clean damper blades and working parts. Do not use petroleum-based products as they could cause excessive dust collection.
- Re-open the damper (move the blade package back to the top of damper) and replace the fusible link.

TESTING DAMPERS

- Use a heat source and melt the fusible link or remove the fusible link and let the blade package drop.
(Caution: keep fingers and hands out of the blade package travel path.)
- Check the blades to make sure they completely close and lock

Notes:

1. Due to their construction (including size) and/or accessibility, curtain type fire dampers may be very difficult and in some cases impossible to test (close and re-open). If the damper is determined to be impossible to test, KBE recommends a thorough examination to ensure nothing exists which would prohibit the damper from closing. A thorough examination should include checking the damper for squareness and the blade channel for obstructions.
2. If possible, DYNAMIC fire dampers should be tested under normal airflow conditions.