



# AIR CONTROL DAMPER MODEL KACAB31 or 41 GALVANIZED AIRFOIL AIR CONTROL DAMPER LOW LEAK

## STANDARD CONSTRUCTION

### FRAME:

16 Ga galvanized steel interlocking hat channel frame construction.

22Ga galvanized steel Flat type frame.

### BLADES:

Double Skin, Galvanized Airfoil Blades

Parallel blades model KACAB31

Opposed blades model KACAB41

### SEALS:

Stainless Steel Jamb Seal

### BEARINGS:

Nylon bearings

### AXLES:

0.47"(12mm) Square zinc plated steel stud

### LINKAGE:

Concealed in frame 10Ga (3mm) zinc plated steel

### MANUAL HAND-QUADRANT:

Galvanized steel die cast hand-quadrant plated for square or round shaft installed on an elevated bearing bracket

### BRACKET:

1" (25mm) elevated hand bracket

### FINISH:

Mill galvanized

## OPTIONS:

### 1) BEARINGS:

Bronze bearings (std for motorized dampers) or stainless steel bearings.

### 2) FRAME CONSTRUCTION

Stainless steel frame construction.

### 3) BLADE CONSTRUCTION

Stainless steel blade construction.

### 4) ACTUATORS:

- Electric (24,120 & 230V) or pneumatic.
- Spring return or non spring return.
- With or without auxiliary switch.

### 5) Blades indicator switch - BIS

### 6) a) FLANGES FOR HAT TYPE FRAME:

Standard duct flanges 35mm (with 1.5mm thickness for damper without sleeve or same as sleeve thickness) or duct mate flanges 35mm

### 6) b) FLANGES FOR FLAT TYPE FRAME:

Standard duct flanges 20mm (with thickness same as flat type frame thickness) or duct mate flanges 35mm

### 7) SLEEVES (Not applicable on Flat type):

Refer to the air control damper sleeve catalogue for standard type of sleeve

### 8) EXTENDED SHAFT (without Hand Quadrant):

4.7" (120mm) extended shaft (round or square) beyond the air control frame.

### 9) 2" Elevated hand bracket.

### 10) Extended frame depth for Flat Type



## APPLICATION

KACAB volume dampers series are designed to provide superior air control with high performance and heavy duty construction. KACAB31 or 41 Dampers are specifically designed for manual balancing applications. They are suitable for use in the majority of commercial medium to high pressure and velocity HVAC systems. They are designed and built to provide a cost effective and reliable dampers for reduced volume control and not positive shut-off.

## MINIMUM SIZES:

### a) SINGLE BLADE FLAT TYPE:

4"W(101mm) x 4"H(101mm).

### b) SINGLE BLADE HAT TYPE:

14"W(355mm) x 6"H(152mm) & 12"W(305mm) x 8"H(203mm) & 6"W(152mm) x 10"H(254mm) & 6"W(152mm) x 12"H(305mm)

### c) MULTI-BLADES :

20"W(508mm) x 12"H(305mm) & 6"W(152mm) x 14"H(355mm)

*Notes: Dampers with width 4" & 5" are only available up to 8" height*

## MAXIMUM SIZES:

### a) SINGLE BLADE FLAT TYPE:

10"W(254mm) x 8"H(203mm) & 12"W(305mm) x 6"H(152mm) & 48"W(1219mm) x 5"H(127mm)

### b) SINGLE BLADE HAT TYPE:

48"W(1219mm) x 10"H(254mm) & 18"W(458mm) x 12"H(305mm)

### c) MULTI-BLADES SINGLE SECTION:

48"W(1219mm)x 48"H(1219mm)

## MULTI-SECTIONS: UNLIMITED

For hat type : dampers are supplied 1/4" less than order WIDTH & HEIGHT unless specified "ACTUAL SIZE"

For flat type : dampers are supplied with "ACTUAL SIZE"



# AIR CONTROL DAMPER MODEL KACAB31 or 41 ORDERING INFORMATION

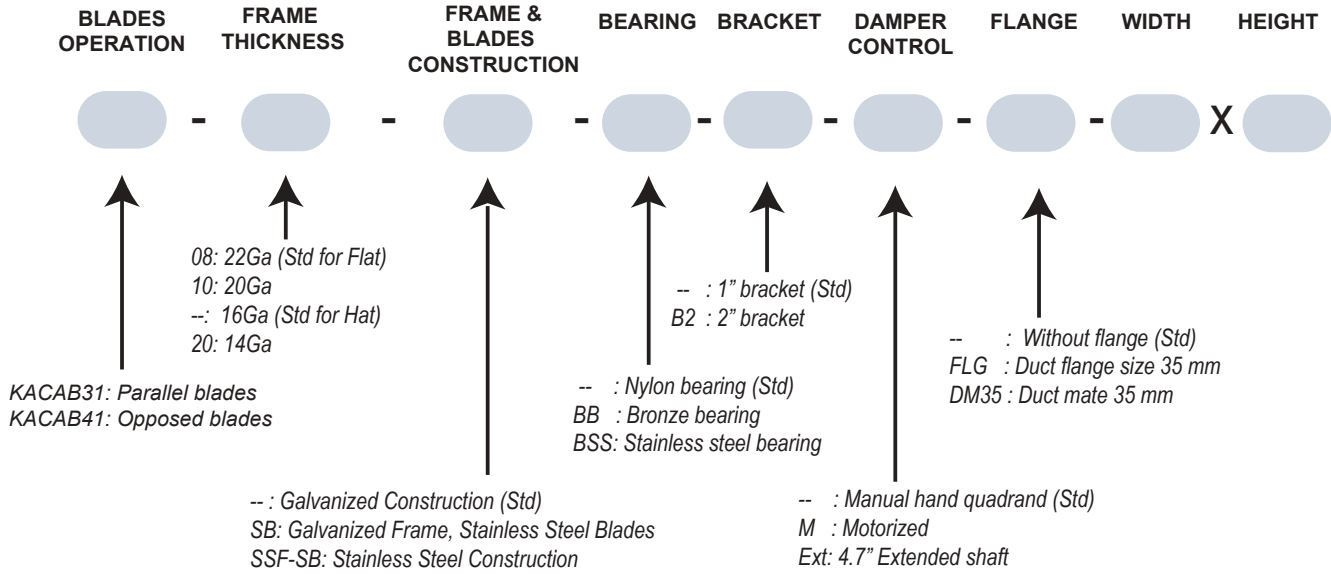

**Example:** KACAB41-BB-M-24x24 -- Motorized damper 24x24 Hat type 16ga galvanized frame & double skin galvanized opposed blades with bronze bearing.  
KACAB31-08-BSS-8x8 - Manual damper 8x8 Flat type with 22ga galvanized frame & double skin galvanized blade with stainless steel bearing

### ACTUATOR SELECTION:

Please select the specifications needed for the actuator:

Electric <input type="checkbox"/>		Pneumatic <input type="checkbox"/>	
24 VAC <input type="checkbox"/>	230VAC <input type="checkbox"/>	Spring return <input type="checkbox"/>	Non spring return <input type="checkbox"/>
Spring return <input type="checkbox"/>	Non spring return <input type="checkbox"/>	Non spring return <input type="checkbox"/>	
On/Off <input type="checkbox"/>	Modulating <input type="checkbox"/>		
With auxiliary switch <input type="checkbox"/>	Without auxiliary switch <input type="checkbox"/>		

Note:  
Volume Dampers with width or height that exceed 48" (1200mm) are manufactured as multiple section and field assembled by others.

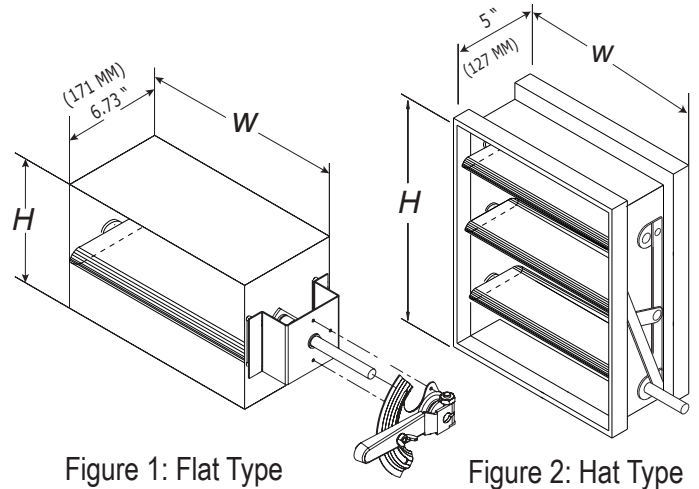

Figure 1: Flat Type

Figure 2: Hat Type

	4	5	6	8	10	12	14	16	18	...	46	48
4	Single Blade Flat Type											
5												
6	Single Blade Hat Type											
8												
10	N/A	Multi Blade Hat Type										
12												
14												
...												
46												
48												

