

FIRE DAMPER MODEL K75
INSTALLATION INSTRUCTIONS

HORIZONTAL MOUNT WITH MULLION FRAME
3 HRS RATING STATIC
(FOR USE IN 4 HOURS FLOOR OPENING)

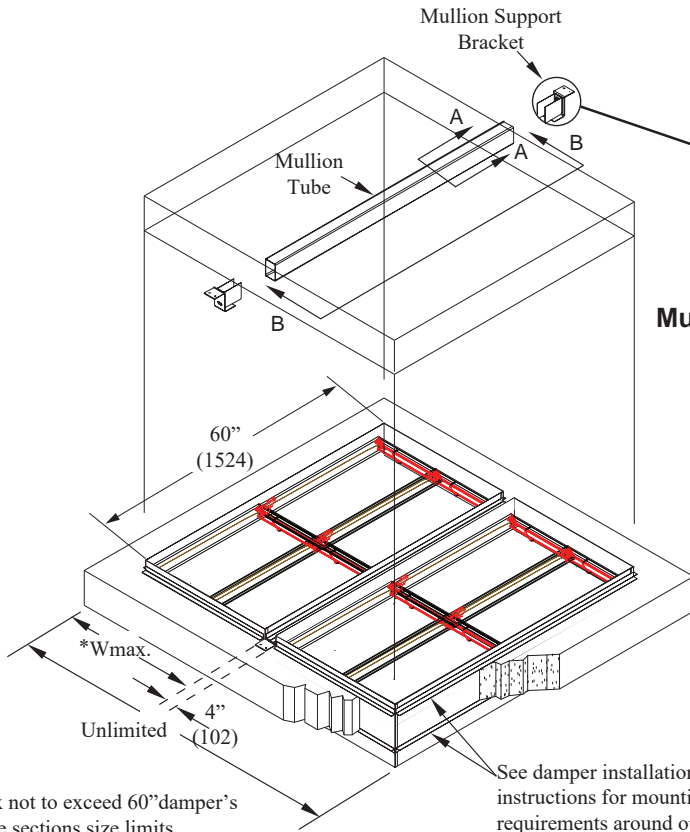

Floor Opening View

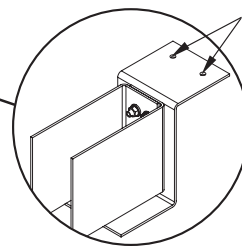

Mullion Support Bracket

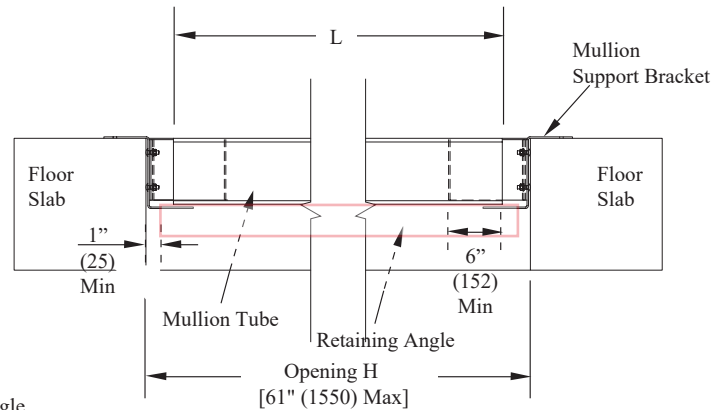

Section B-B

Application

Support mullions allow oversized openings in fire resistant rated floors to be subdivided into smaller openings that do not exceed the fire damper's maximum rated size limits. Whenever the duct size exceeds the maximum damper width, the opening must be divided into two or more separate openings with a mullion installed between horizontally mounted damper sections. The support mullion consists of a structural steel tube and two mullion support brackets. Maximum mullion spans must not exceed 60" (1550). The mullions are not intended to be in the airstream and are not part of the duct work. The horizontal steel mullion is intended for use in fire resistant floors rated to a maximum of 4 hours.

General Installation

Insert one mullion support bracket into each end of the mullion tube allowing the tube to float between the brackets. DO NOT fasten the brackets to the tube in any way. Locate in the opening to provide correct expansion clearance for the dampers. Refer to Damper Installation Instructions for details. Drill 1/16" (8) diameter holes in the mullion support brackets for anchoring. Drill 1/2" (12.5) diameter holes in the Concrete and introduce the M8 RawlBolt (8mm steel concrete anchors) for anchoring. Each bracket must be anchored to concrete in at least 2 places with a M8x70mm bolts. (Construction Details figure 2).

Retaining Angle on the BOTTOM of the mullion Frame shall be cut short to allow 1/8 in. per ft expansion clearance at ends, if the angles are located within the confines of the floor opening. The retaining angles at top of floor at the mullion are to overlap the floor at each end by min 1 in.

Galvanized coat structural steel mullion tube in accordance with local code requirements.

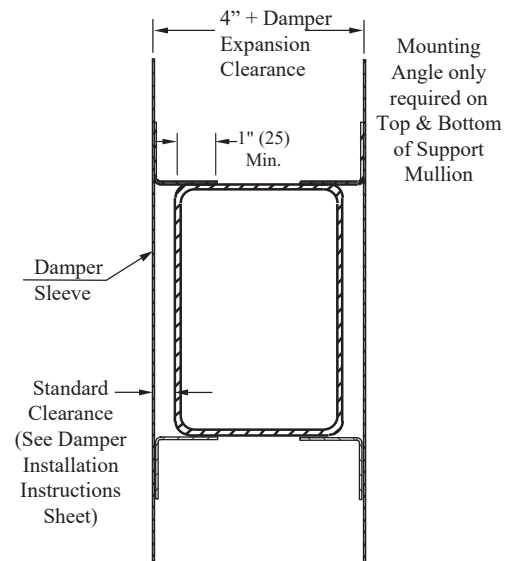

Section A-A



NOTE: Size in () are in mm

FIRE DAMPER MODEL K75
INSTALLATION INSTRUCTIONS

HORIZONTAL MOUNT WITH MULLION FRAME
3 HRS RATING STATIC
(FOR USE IN 4 HOURS FLOOR OPENING)

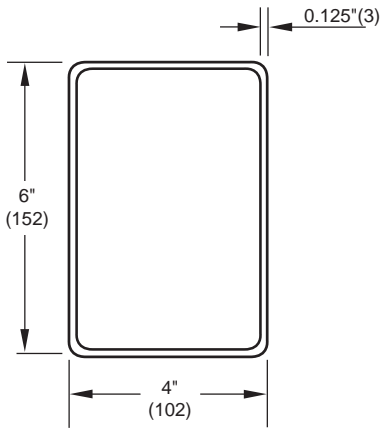

Figure 1: Mullion Tube

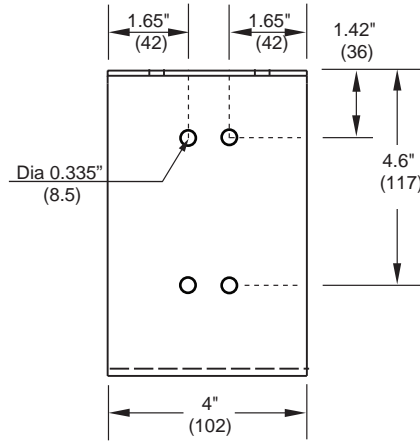

Figure 3: Shelf Bracket

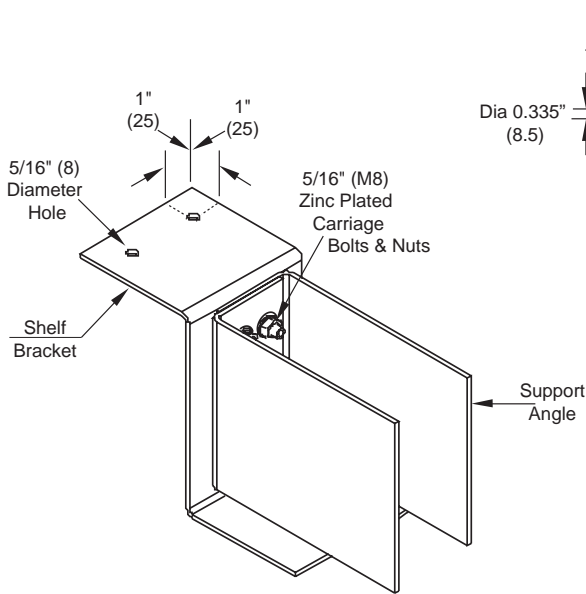
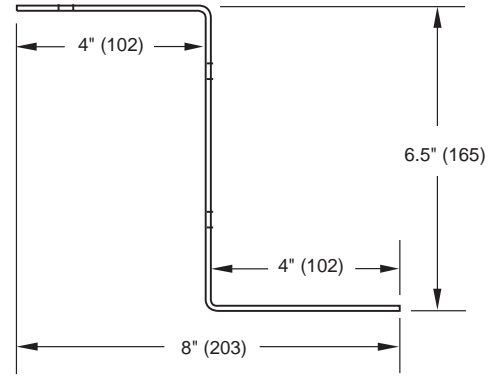

Figure 2: Mullion Support Bracket

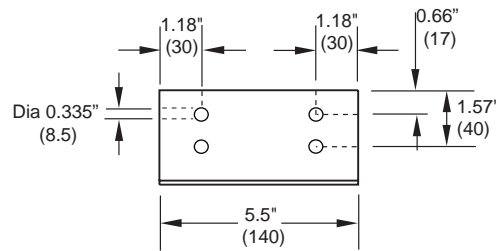
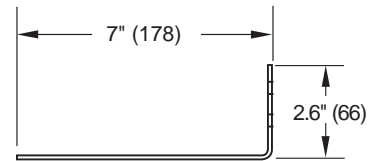

Figure 4: Support Angle



Construction

Fabricate mullion tubes from 6" x 4" x 1/8" thick (152 x 102 x 3) hot rolled steel tubing (Construction Fig 1). Size mullion tube to be a 2 ± 1/2" (51 ± 13) shorter than the height of the rough opening. Fabricate two mullion support brackets per each mullion tube from 10 gauge (3.5) galvanized steel (Construction Details Fig 2). The brackets are to be assembled from one shelf bracket and from two support angles (See Construction Details Fig 3 & 4). The shelf bracket and support angles must be bolted together with minimum 5/16" x 1" (M8 x 25) diameter zinc plated or stainless steel carriage bolts to create the mullion support bracket. The mullion tube must overlap each support bracket by a minimum of 6" (152) (See Detail B-B).